



A detector for the measurement of the ultrarare decay $K^+ \rightarrow \pi^+ \nu \nu$: *NA62 at CERN SPS*

13th ICATPP Conference

Villa Olmo, Como 03-07 October 2011

Roberto Piandani
INFN and Perugia University

On behalf of the NA62 Collaboration

Outline

- ✓ The $K \rightarrow \pi \nu \nu$ in the SM and beyond
- ✓ NA62 experimental technique
- ✓ NA62 experiment:
 - ✗ Signal & background
 - ✗ Detectors
 - ✗ Trigger
 - ✗ Sensitivity
- ✓ NA62 Schedule
- ✓ NA62 Phase I
- ✓ Conclusions

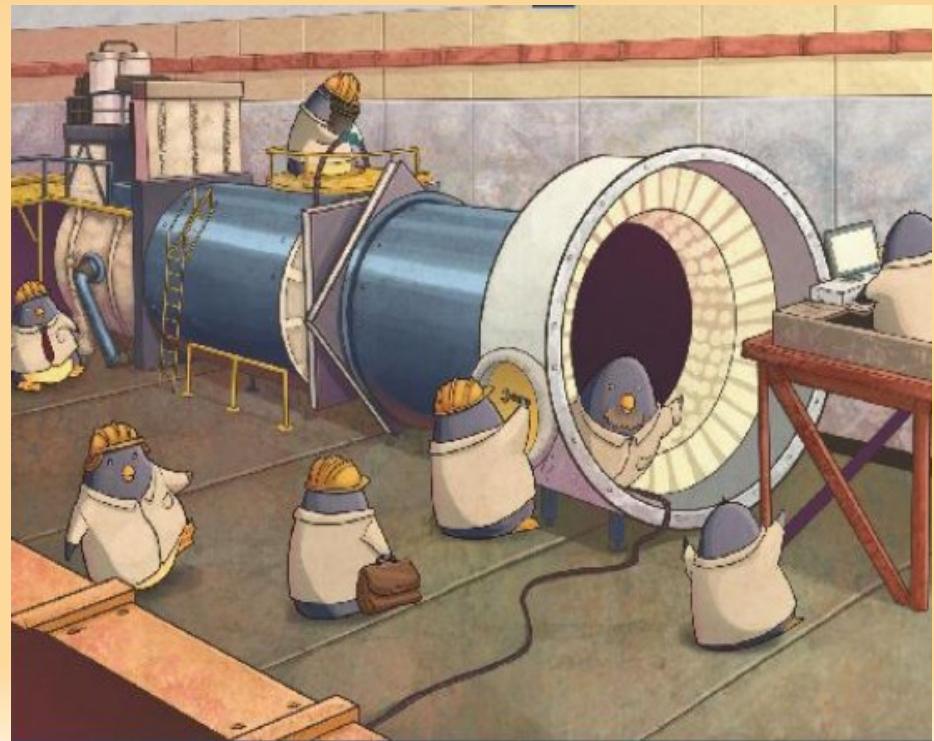

$K^+ \rightarrow \pi^+ \nu \nu$ in the Standard Model

- FCNC process forbidden at tree level
- Short distance contribution dominated by **Z penguins** and box diagrams
- Negligible contribution from u quark, small contribution from c quark
- **Very small BR** due to the CKM top coupling $\rightarrow \lambda^5$

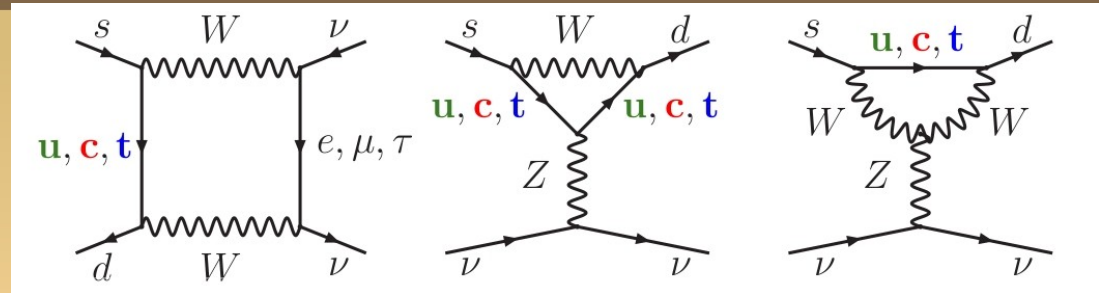

- ✓ Amplitude well predicted in SM (measurement of V_{td} without QCD inputs)
- ✓ Residual error in the BR due to parametric uncertainties (mainly due to charm contributions): $\sim 7\%$

	$\Gamma_{\text{SD}}/\Gamma$	Irr. theory err.	BR x 10^{-11}
$K_L \rightarrow \pi \nu \nu$	>99%	1%	3
$K^+ \rightarrow \pi^+ \nu \nu$	88%	3%	8
$K_L \rightarrow \pi^0 e^+ e^-$	38%	15%	3.5
$K_L \rightarrow \pi^0 \mu^+ \mu^-$	28%	30%	1.5

$K^+ \rightarrow \pi^+ \nu \nu$ beyond the SM

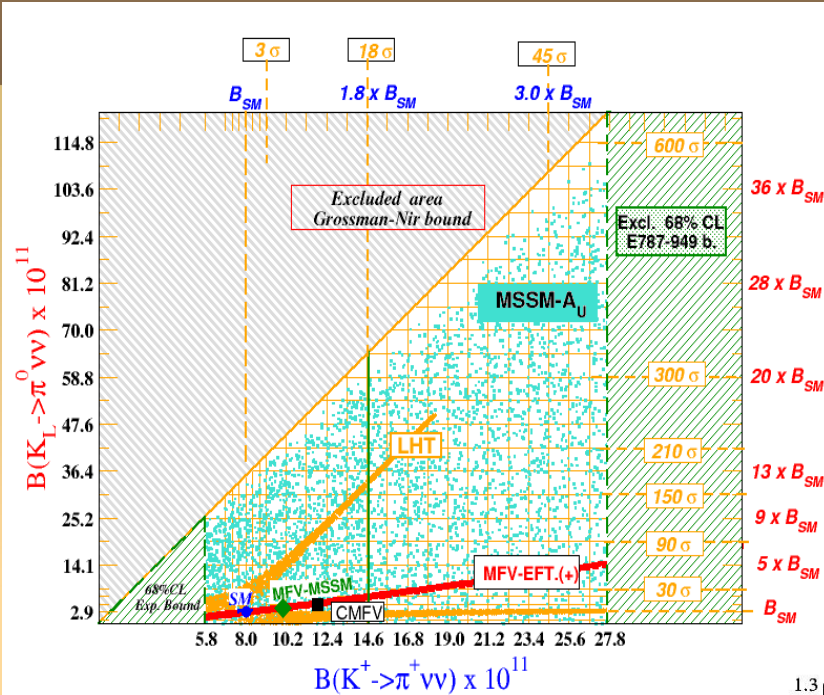

- ✗ Stringent test of the SM
- ✗ Several SM extensions predict different value for the BR
- ✗ Possibility not only to identify new physics but also to distinguish among different models: *SUSY*, *MSSM* (with or without new sources of CPV or FV)

- Example: in MSSM the departure from the SM should reach 10%-20% for reasonable parameters values
- Higher effects with respect to the B decays

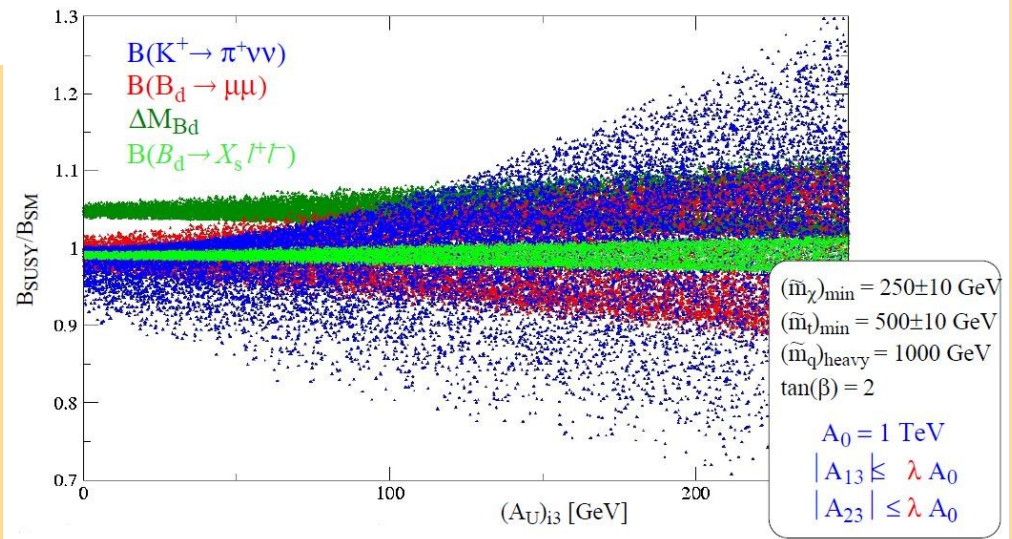

Experimental technique

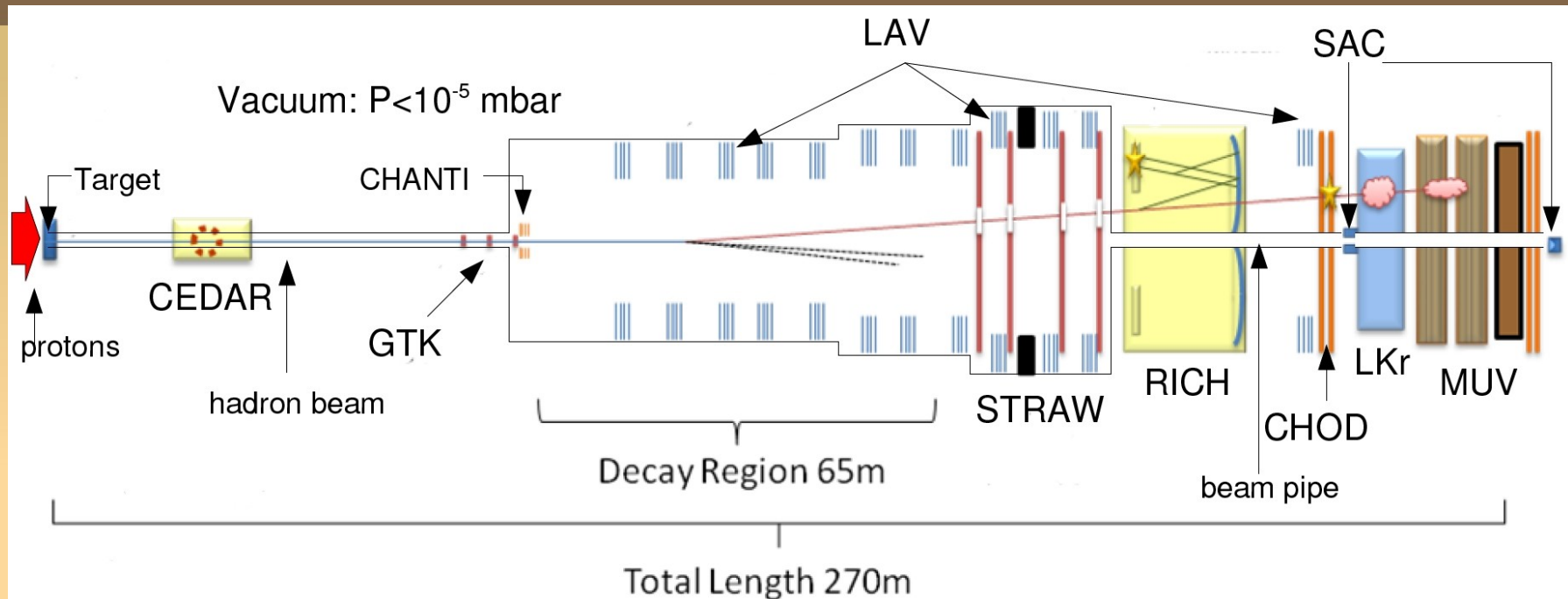

- Kaon decay **in-flight** from an **unseparated 75 GeV/c** hadron beam, produced with 400 GeV/c protons from SPS on a fixed berilium target
- **~800 MHz** hadron beam with **~6% kaons**
- The pion decay products in the beam remain in the beam pipe
- **Goal:** measurement of **O(100)** events in two years of data taking with **% level of systematics**
- Present result (E787+E949): 7 events, total error of ~65% (Phys.Rev. D79 (2009) 092004).

Experimental technique

→ Very challenging experiment:

- ✓ Weak signal signature: $BR_{SM}=8 \times 10^{-11}$
- ✓ Potentially huge background from kaon decays

Key points:

1. Kinematical rejection
2. Vetos
3. Particle identification
4. Trigger

Decay	BR
$\mu^+ \nu$ (K μ 2)	63.5%
$\pi^+ \pi^0$ (K π 2)	20.7%
$\pi^+ \pi^+ \pi^-$	5.6%
$\pi^0 e^+ \nu$ (Ke3)	5.1%
$\pi^0 \mu^+ \nu$ (K μ 3)	3.3%
$\pi^+ \pi^0 \pi^0$	1.8%
$\mu^+ \nu \gamma$ (K μ 2 γ)	0.62%
$\pi^+ \pi^0 \gamma$	2.7×10^{-4}
$\pi^+ \pi^- e^+ \nu$ (Ke4)	4.1×10^{-5}
$\pi^0 \pi^0 e^+ \nu$ (Ke400)	2.2×10^{-5}
$e^+ \nu$ (Ke2)	1.5×10^{-5}
$\pi^+ \pi^- \mu^+ \nu$ (K μ 4)	1.4×10^{-5}

1) Kinematic rejection

$$m_{miss}^2 \cong m_K^2 \left(1 - \frac{|P_\pi|}{|P_K|} \right) + m_\pi^2 \left(1 - \frac{|P_K|}{|P_\pi|} \right) - |P_K| |P_\pi| \theta_{\pi K}^2$$

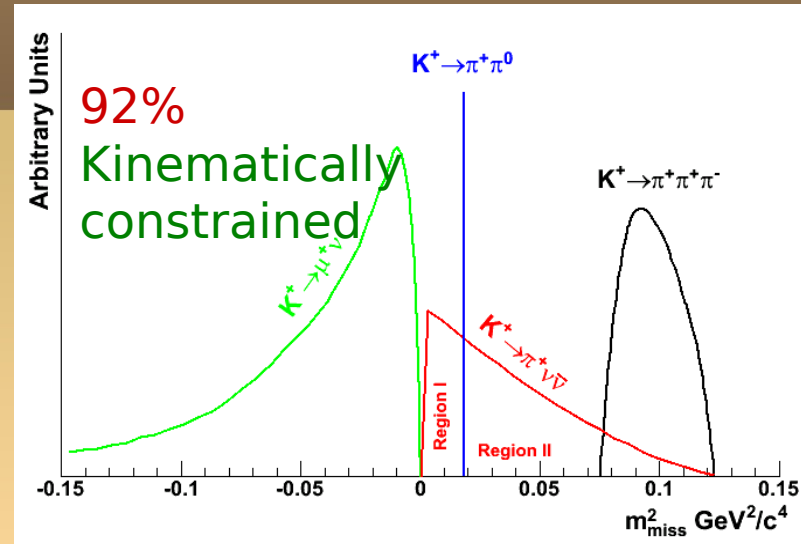

- ✗ The missing mass will be used to identify **two regions** with lower background level
- ✗ Measurement of kaon and pion momenta

Kaon momentum : Gigatracker

- **Thin** detector → **200 μm** pixel sensor + **100 μm** readout chip (< 0.5% X_0 per station)
- **18000** pixels, **150 kHz** rate per single pixel in the central part
- Excellent **time resolution** to match the measurement with the other detectors → **<200 ps** per station achieved in test beam

Charged pion momentum: Straw tracker

- **4 chambers** with 4 redundant views each (4 staggered layer per view)
- Magnet with **$P_{kick} = 256$ MeV/c**
- **2.1 m** long straws, **9.6 mm** mylar tubes
- **<0.1% X_0** per view

2) Vetos: LAV and LKr

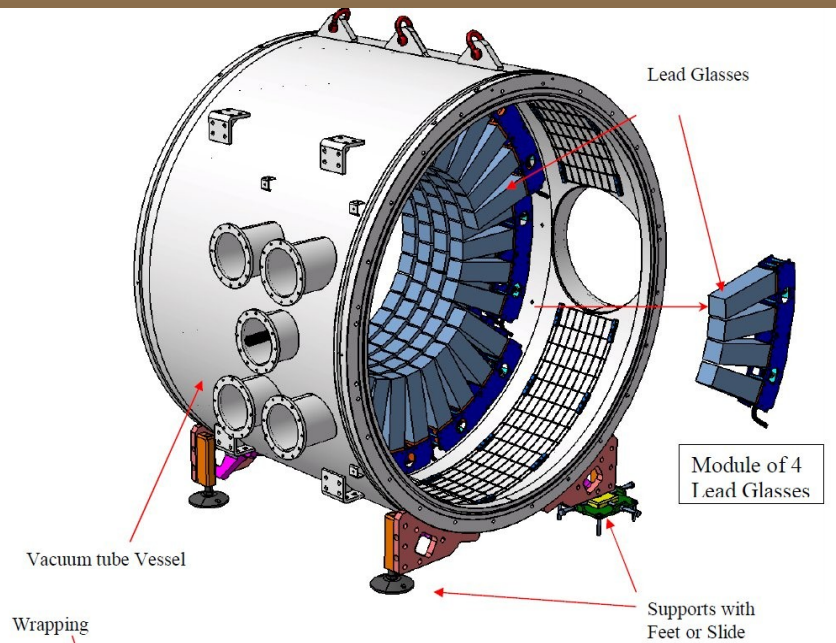

LAV:

- 12 rings along the decay region (in vacuum)
- Fully angular coverage in the 8.5-50 mrad range
- OPAL calorimeter lead glass reused: 5 staggered rings per station
- Block tested at BTF@Frascati: inefficiency $< 10^{-4}$ for 476 MeV e^+
- Time resolution: 700 ps

The old NA48 electromagnetic calorimeter, cryogenic liquid krypton (Lkr):

- ✓ Quasi homogeneous ionization chamber
- ✓ more than 13000 channels
- ✓ 27 X_0
- ✓ Excellent energy resolution
- ✓ very good time resolution: 100 ps
- ✓ New readout electronics: 14 bits 40 MHz ADC with large buffers

✓ The performances as photon veto has been measured in a special run with 75 GeV kaon decays:

Energy(GeV)	Inefficiency
2.5-5.5	10^{-3}
5.5-7.5	10^{-4}
7.5-10	5×10^{-5}
>10	8×10^{-6}

For more detail see the next talk of Andrea Salamon

3) PID: CEDAR

- ✗ Positive identification of the kaon in the hadron beam
- ✗ **Purpose:** tagging the kaon to **decrease** the requirements for the vacuum in the decay region (10^{-5} mbar).
- ✗ **Technique:** differential H₂ cherenkov detector.
- ✗ Old detector built at CERN in the '70
- ✗ New readout (PMTs and electronics)
- ✗ New **deflecting mirrors** system to decrease the rate per single channel on the readout.

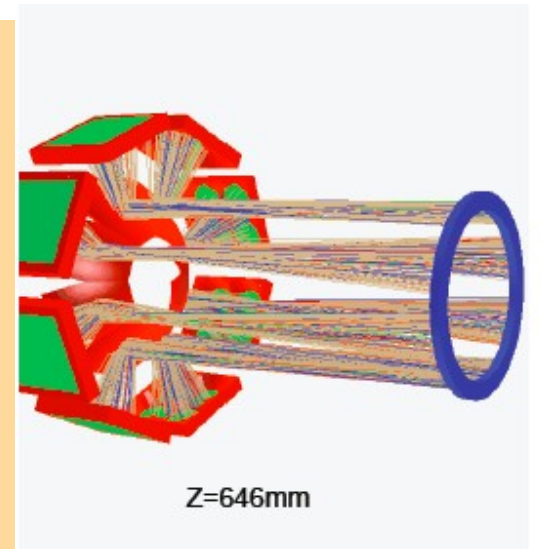
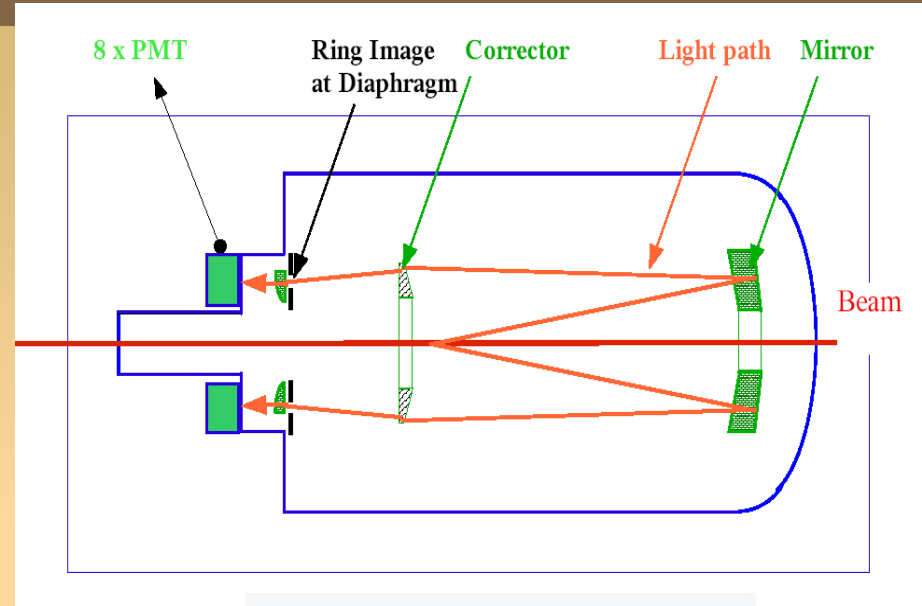

For more detail see the talk of Angela Romano (tomorrow)

3) PID: RICH

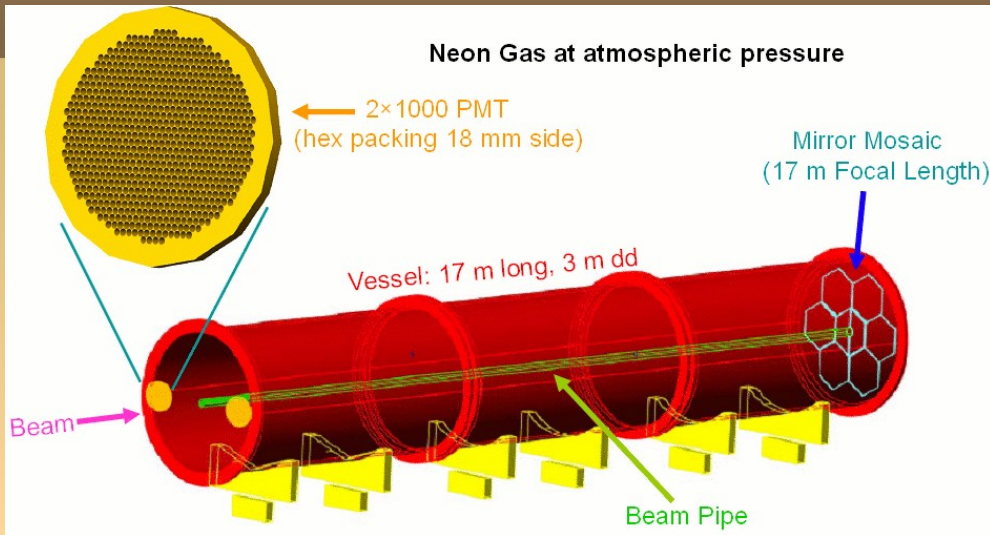

- ➔ 17 m long, 3 m in diameter
- ➔ Filled with 1 atm Neon
- ➔ π - μ separation in the 15-35 GeV/c range
- ➔ Cherenkov light collected in two spots: 1000 PM each
- ➔ Full length prototype tested in 2009
- ➔ Average time resolution: 70 ps
- ➔ Integrated mis-identification probability: $\sim 5 \times 10^{-3}$

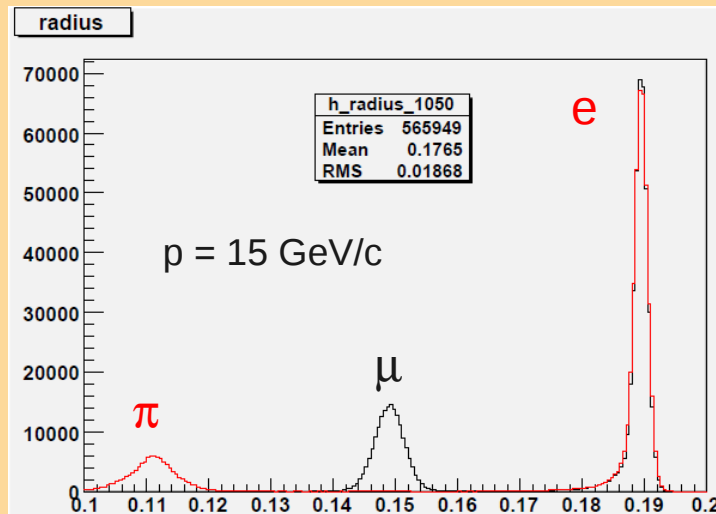

For more detail see the talk of Francesca Bucci (tomorrow)

3) PID: MUV

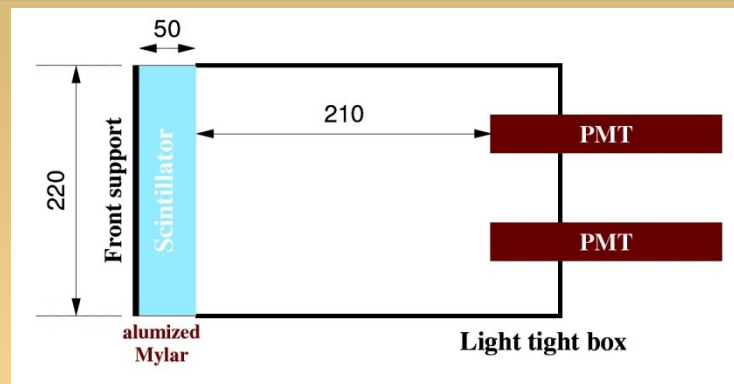
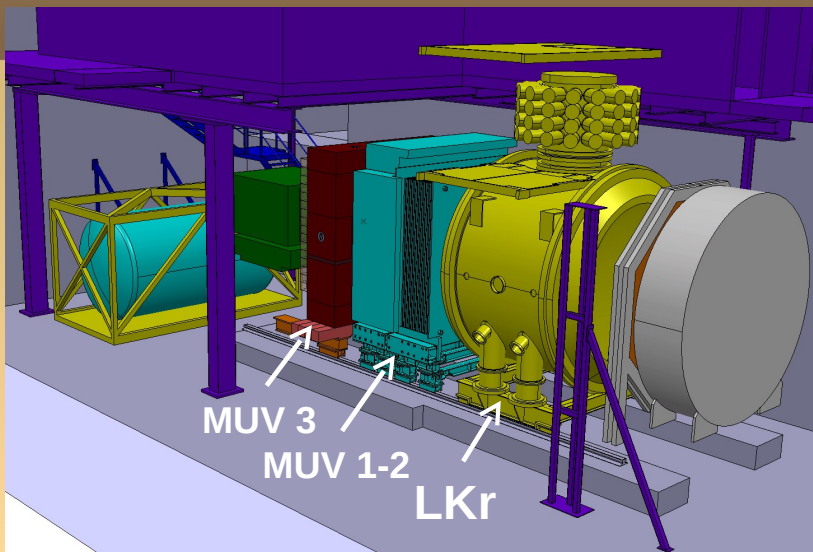

- **MUV1-2** : to reach a factor of 10^6 in muon rejection (combined with the RICH)
 - Iron and scintillator
- **MUV3**: fast muon identification plane for trigger
 - modules of 22x22 cm² with 5 cm thick scintillator readout with 2 PMs
 - **<1ns** time resolution achieved in test beam

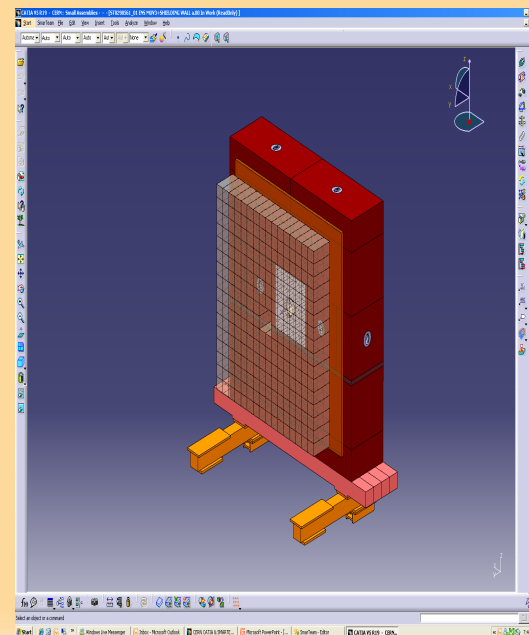

NA62 sensitivity

$K^+ \rightarrow \pi^+ \nu \nu$ (signal)	45 events/year
$K^+ \rightarrow \pi^+ \pi^0$	4.3% (2.3 evts)
$K^+ \rightarrow \mu^+ \nu$	2.2% (1.2 evts)
$K^+ \rightarrow \pi^+ \pi^- e^+ \nu$	<3% (1.7 evts)
3 tracks	<1.5% (0.8 evts)
$K^+ \rightarrow \pi^+ \pi^0 \gamma$	~ 2% (1.1 evts)
$K^+ \rightarrow \mu^+ \nu \gamma$	~ 0.7% (0.4 evts)
others	negligible
Expected bkg	<13.5% (7.4 evts)

- $\sim 5 \cdot 10^{12}$ decay per year
- O(10%) signal acceptance
- 100% trigger efficiency assumed

NA62 Schedule

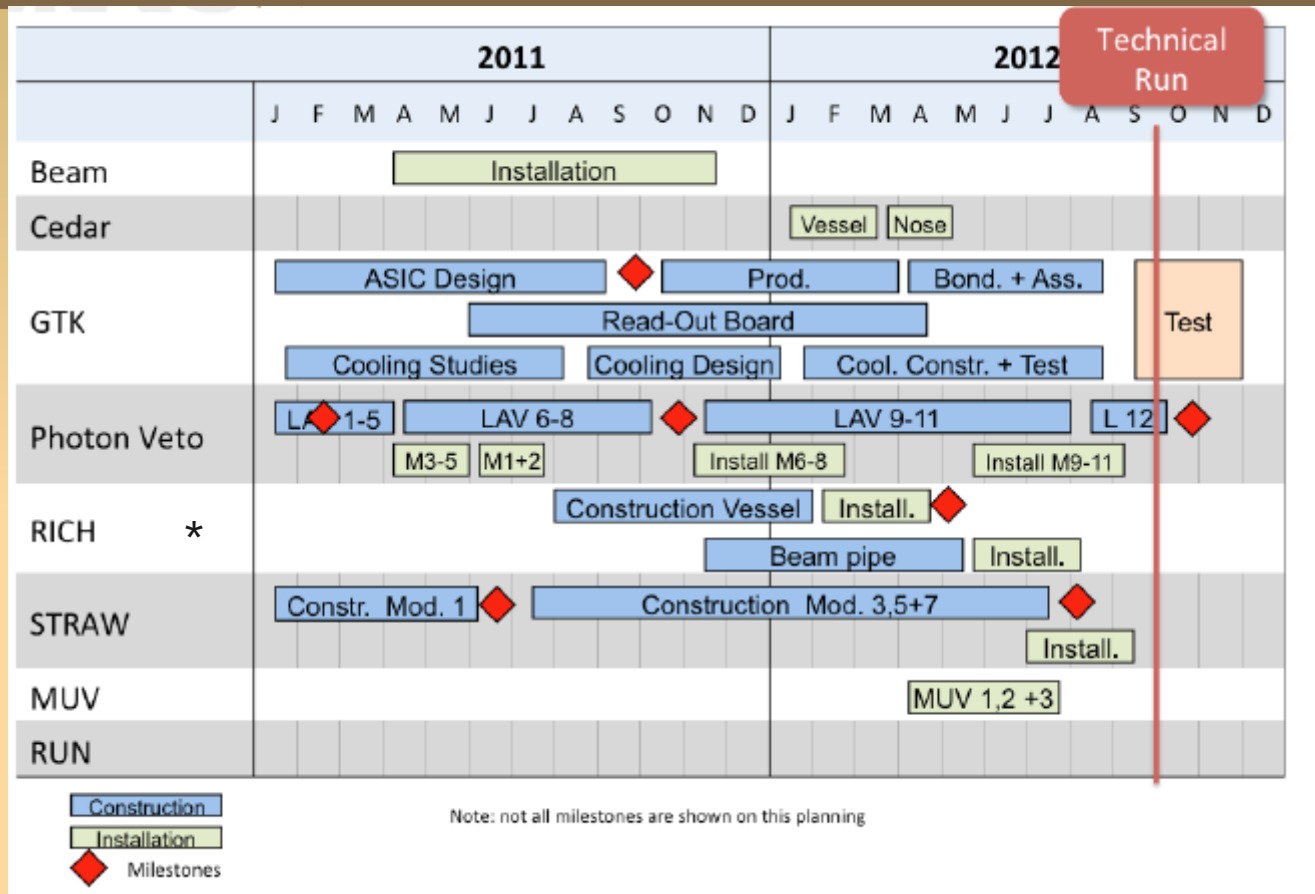

✓ Physics Run: 2014/15 after the LHC shutdown.

* 4 months of delay due to the new specification of the vessel, the new one has to work in vacuum.

NA62 Phase I

The NA62 collaboration performed a precision measurement of $R_K = BR(K^+ \rightarrow e^+ \nu) / BR(K^+ \rightarrow \mu^+ \nu)$ using data collected in 2007 and 2008.

$$R_K = (2.488 \pm 0.007_{\text{stat}} \pm 0.007_{\text{syst}}) \times 10^{-5} \\ = (2.488 \pm 0.010) \times 10^{-5}$$

Uncertainty source	$\delta R_K \times 10^5$
Statistical	0.007
$K_{\mu 2}$ background	0.004
$K^\pm \rightarrow e^\pm \nu \gamma$ (SD ⁺)	0.002
$K^\pm \rightarrow \pi^0 e^\pm \nu, K^\pm \rightarrow \pi^\pm \pi^0$	0.003
Beam halo background	0.002
Helium purity	0.003
Acceptance correction	0.002
DCH alignment	0.001
Electron identification	0.001
1TRK trigger efficiency	0.001
LKr readout efficiency	0.001
Total uncertainty	0.010

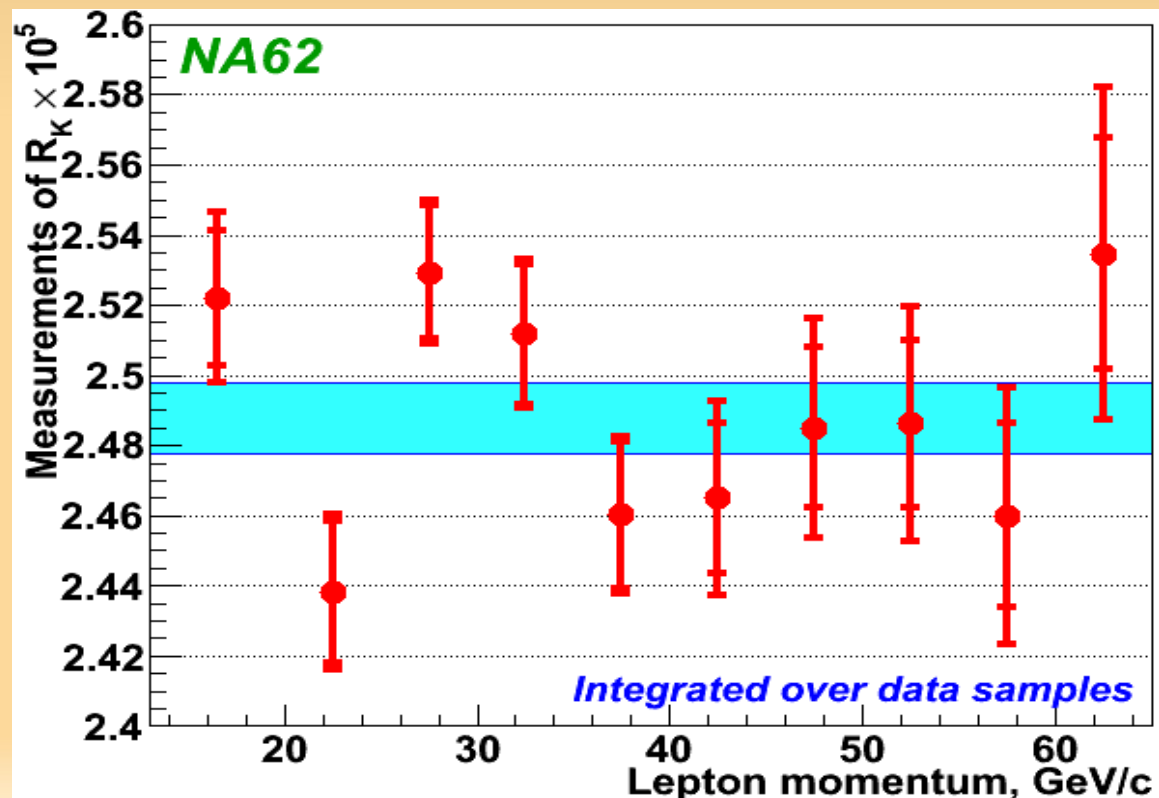

Conclusions

- Clear physics case, sensitivity to New Physics: complementary to LHC
- Goal to reach $O(100)$ SM events in 2 years of data taking.
- **Very challenging experiment:**
 - High intensity beam
 - High resolution in kinematical reconstruction
 - High time resolution in all the detectors
 - High veto efficiency
 - Good particle identification
 - NA62 detectors have been carefully designed and validated (R&D, tests and Monte Carlo.)
- **Schedule:**
 - 2006-2009: R&D
 - 2010-2012: Construction
 - End of 2012: Technical run
 - 2014/15: Physics run
- The Phase I of the NA62 has obtained a precise measurement of the ratio R_K ($\sim 0.4\%$)

Spare

1) Kinematic rejection: Gigatracker

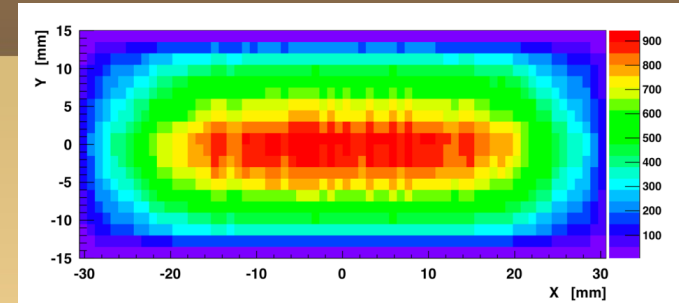
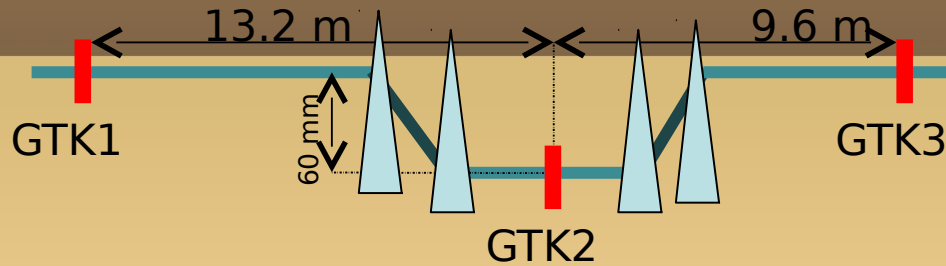

- Momentum reconstruction on high intensity beam → **three stations** in an achromath dipole system
- **Thin** detector → **200 μm** pixel sensor + **100 μm** readout chip (<0.5% X_0 per station)
- **18000** pixels, **150 kHz** rate per single pixel in the central part
- Excellent **time resolution** to match the measurement with the other detectors → **<200 ps** per station achieved in test beam
- Cooling system to control the leakage current given by the radiation damage → **microchannel cooling** or standard cooling in **light material vessel**.

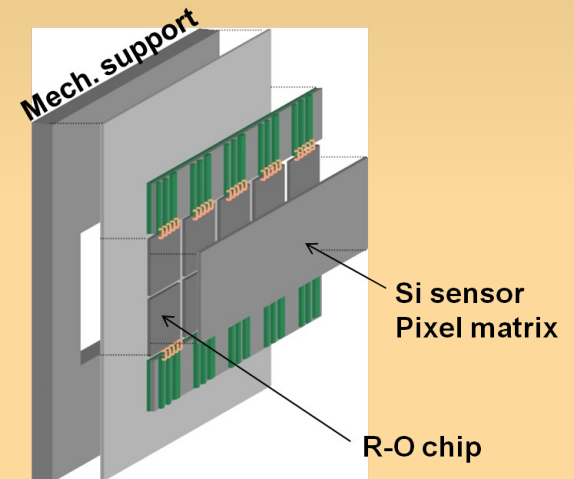

$$\sigma(\text{PK})/\text{PK} \sim 0.2\%$$

$$\sigma(dX/dZ)/(dX/dZ) \sim 16 \mu\text{rad}$$

1) Kinematical rejection: Straws tracker

- Spectrometer in **vacuum** to decrease MS effects
- **4 chambers** with 4 redundant views each (4 staggered layer per view)
- Magnet with $P_{kick} = 256 \text{ MeV}/c$
- **2.1 m** long straws, **9.6 mm** mylar tubes
- $<0.1\%$ X_0 per view
- Central “hole” (6 cm radius) for the beam obtained removing straw tubes in the central region
- Full length prototype built and tested in vacuum at SPS@CERN in 2007 and 2010

$$\sigma(P\pi)/P\pi \sim 0.3\% + 0.007\% * P\pi \text{ (GeV}/c)$$

$$\sigma(dX/dZ)/(dX/dZ) \sim 45\text{-}15 \mu\text{rad}$$

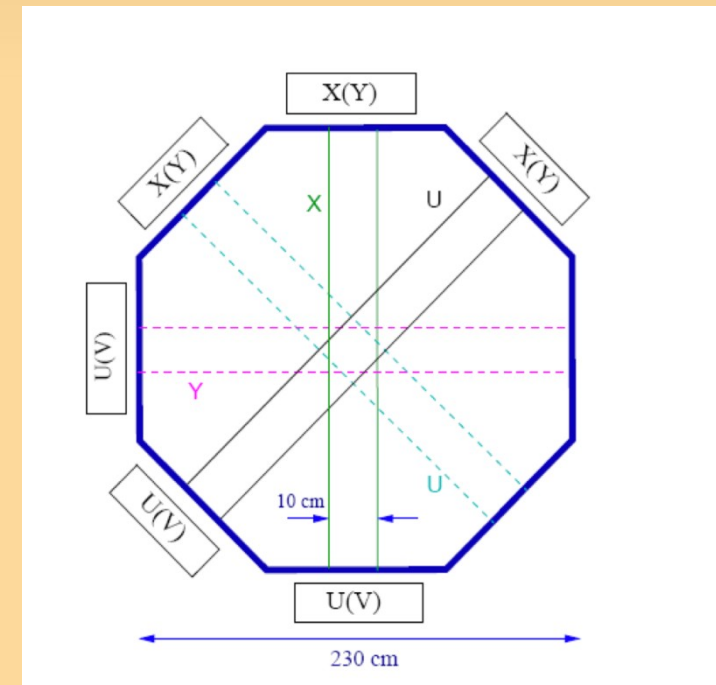
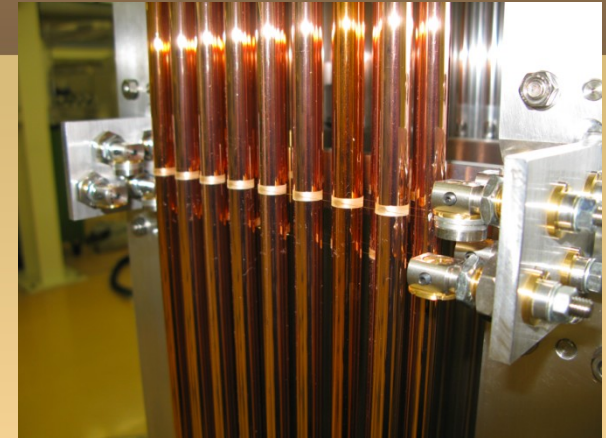

Not kinematically constrained background

- ✗ ~8% of the Kaon decays is not kinematically constrained.
- ✗ Rejection is based solely on **veto and particle identification**.
- ✗ The veto and PID are exploited to reach the 10^8 **rejection** factor in the kinematical constrained background

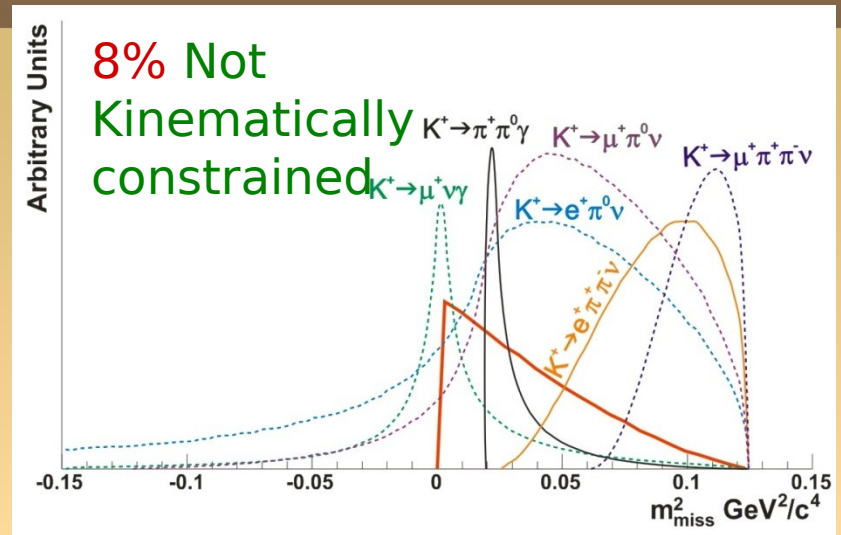

Veto system requirements:

- ✗ Large angle (8.5-50 mrad): inefficiency $<10^{-4}$ for γ between 100 MeV and 35 GeV
- ✗ Forward veto (1-8.5 mrad): inefficiency $<10^{-5}$ for $E > 10$ GeV
- ✗ Small angle (<1 mrad): $<10^{-3}$ for $E > 10$ GeV

PID system requirements:

- ✗ Positive kaon identification in the hadron beam
- ✗ $\pi-\mu$ separation: 10^{-3} mis-identification probability

4) Trigger

- L0 selection: **RICH+!LKR+!MUV3**
 - **RICH**: hit multiplicity positive signal
 - **!LKR**: no 2 clusters more than 30 cm apart
 - **!MUV3**: no signal in MUV3
- Very good time resolution is required to avoid **random veto**
- At the software levels a more complete analysis will be performed (missing mass, Z vertex,...)

	Initial rate (MHz)	After L 0 (MHz)
$\pi\pi^0$	1.9	0.22
$\mu\nu$	5.7	0.04
$\pi\pi\pi$	0.5	0.1
$\pi\pi\pi^0$	0.16	0.002
$\pi^0 e\nu$	0.3	0.05
$\pi^0\mu\nu$	0.2	0.002
TOT	6.7	0.4
$\pi\nu\nu$ (eff.)		82%