



# ***New NA48 Results on Kaon and Hyperon Decays***

**Rainer Wanke**

(for the NA48 Collaboration)

Institut für Physik, Universität Mainz

**ICHEP 2006**

Moscow, July 29, 2006

## ■ The NA48 Experiment

## ■ Hyperons: $\Xi^0$ Decays

■  $\Xi^0$  Decay Asymmetries

■  $\Xi^0$  Lifetime

## ■ Kaon Decays

■  $K^\pm \rightarrow \pi^\pm \pi^0 \gamma$  Decays

■  $K_{\mu 3}^0$  Form Factors

## ■ Summary

1997	$\epsilon'/\epsilon$ run	$K_L + K_S$
1998	$\epsilon'/\epsilon$ run	$K_L + K_S$
1999	$\epsilon'/\epsilon$ run $K_L + K_S$	$K_S$ Hi. Int.
2000	$K_L$ only NO Spectrometer	$K_S$ High Intensity
2001	$\epsilon'/\epsilon$ run $K_L + K_S$	$K_S$ High Int.
2002	$K_S$ High Intensity	
2003	$K^\pm$ High Intensity	
2004	$K^\pm$ High Intensity	

# The NA48 Detector

## Detector components:

### ■ Magnet spectrometer

4 sets of drift chambers.

$$\Delta p/p \approx 0.5\% \quad \text{for } p = 20 \text{ GeV}/c.$$

### ■ Hodoscopes:

Fast trigger, precise time measurement ( $\sigma_t = 150 \text{ ps}$ ).

### ■ Liquid Krypton Calorimeter (LKr)

$$\Delta E/E \approx 1.0\% \quad \text{for } E_{e,\gamma} = 20 \text{ GeV}/c.$$

### ■ Hadron calorimeter, photon vetos, muon counters

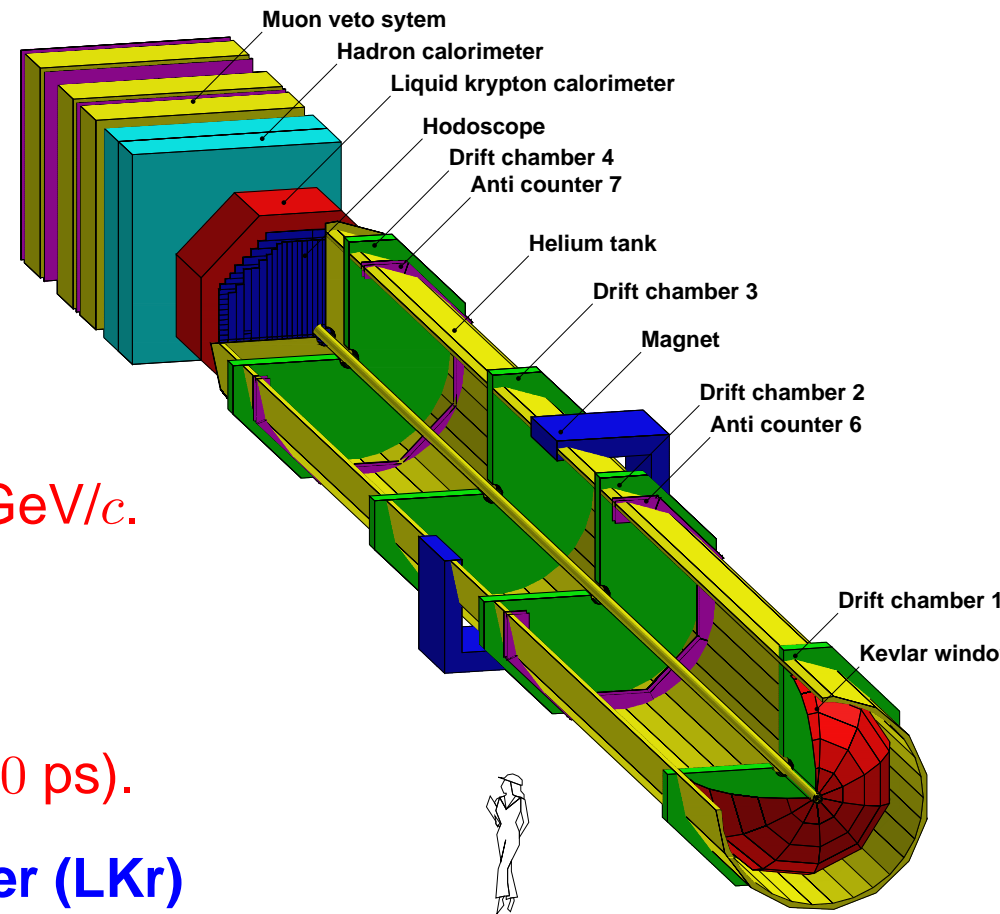

# $K_S$ and $\Xi^0$ Decays: The NA48/1 Experiment

Data taking in 2002: (NA48/1 experiment)

- **Purpose:** Measurement of very rare  $K_S$  decays and neutral Hyperon decays.
- **Neutral beam** with target close decay region.  
( $K_S$  target from  $e'/e$  measurement, but  $200\times$  intensity.)
- **Total statistics:**  $K_S$  flux:  $\sim 3.5 \times 10^{10}$   
 $\Xi^0$  flux:  $\sim 2.4 \times 10^9$  in the decay region.

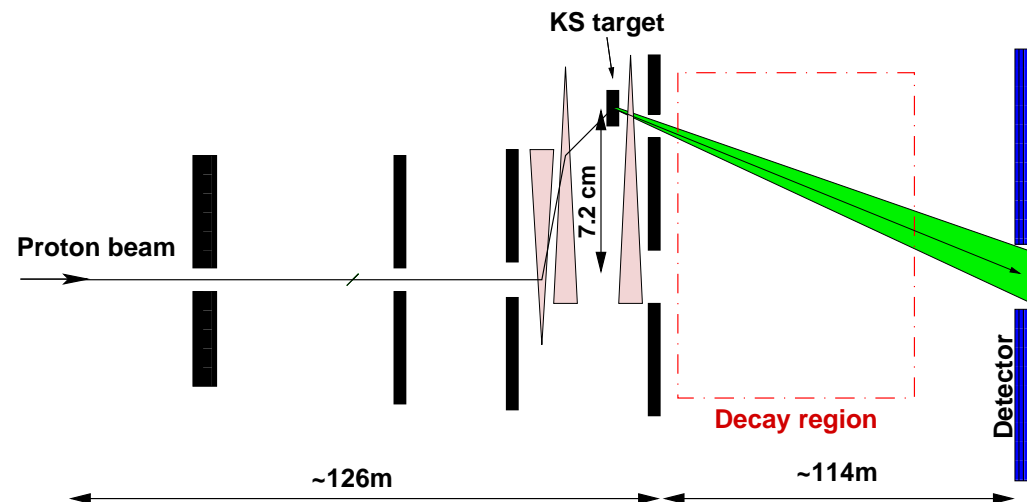

# Weak Radiative $\Xi^0$ Decays

## Weak Radiative Hyperon Decays: ( $\Xi^0 \rightarrow \Lambda\gamma$ , $\Xi^0 \rightarrow \Sigma^0\gamma$ , ...)

- All interactions (weak, strong, e.m.) involved.
- Several competing theoretical models (pole models, quark models, VMD, ...)

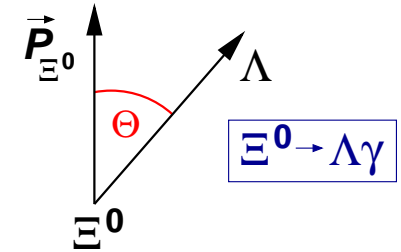

## Decay Asymmetry in Hyperon Decays:

$$\frac{dN}{\cos \Theta} = N_0(1 + \alpha \cos \Theta)$$

- Very different theoretical predictions for decay asymmetries.
- Method for  $\Xi^0 \rightarrow \Lambda\gamma$ : Measure  $\cos \Theta_\Lambda$  between  $\Xi^0$  and  $p$  from  $\Lambda \rightarrow p\pi^-$ .  
 $\implies$  Independent from  $\Xi^0$  polarisation!
- $\Xi^0 \rightarrow \Sigma^0\gamma \rightarrow (\Lambda\gamma)\gamma$ :  
 Build product  $\cos \Theta_{\Xi \rightarrow \Sigma\gamma} \cdot \cos \Theta_{\Sigma \rightarrow \Lambda\gamma}$ .

sign of $\alpha$	$\Xi^0 \rightarrow \Lambda\gamma$	$\Xi^0 \rightarrow \Sigma^0\gamma$
pole	-	-
QM, VMD	+	-

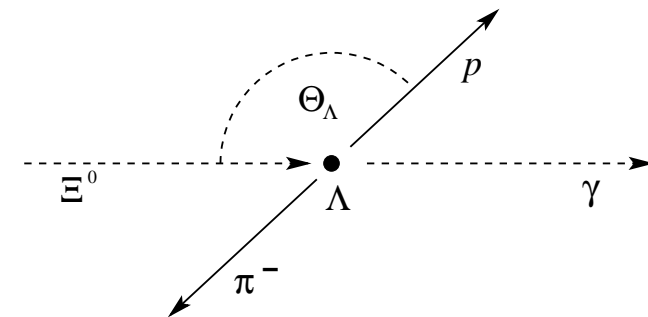

# $\Xi^0 \rightarrow \Lambda \gamma$ Decay Asymmetry

$\Xi^0 \rightarrow \Lambda \gamma$  : 43814 decay candidates.

Background: 0.8% ( $\Xi^0 \rightarrow \Lambda \pi^0$ , accidental overlaps)

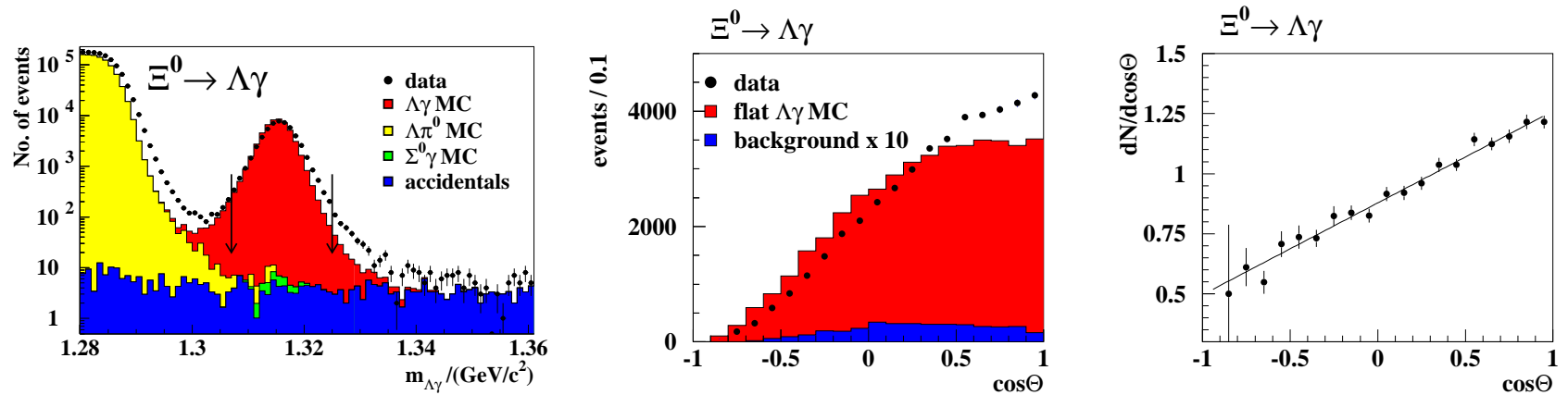

- Fit result:  $\alpha_{\Xi^0 \rightarrow \Lambda \gamma} \cdot \alpha_{\Lambda \rightarrow p \pi} = -0.439 \pm 0.013_{\text{stat}} \pm 0.038_{\text{syst}}$   
(Systematics mainly from energy dependence, trigger efficiency.)

- Use  $\alpha_{\Lambda \rightarrow p \pi} = 0.642 \pm 0.013$  [PDG]: (NA48/1 preliminary)

$$\alpha_{\Xi^0 \rightarrow \Lambda \gamma} = -0.684 \pm 0.020_{\text{stat}} \pm 0.061_{\text{syst}}$$

(Previous measurement:  $\alpha = -0.78 \pm 0.19$  [NA48, 2003])

# $\Xi^0 \rightarrow \Sigma^0 \gamma$ Decay Asymmetry

$\Xi^0 \rightarrow \Sigma^0 \gamma$  : **13068 decay candidates.**

Background:  $\approx 3\%$  (Mainly  $\Xi^0 \rightarrow \Lambda \pi^0$ )

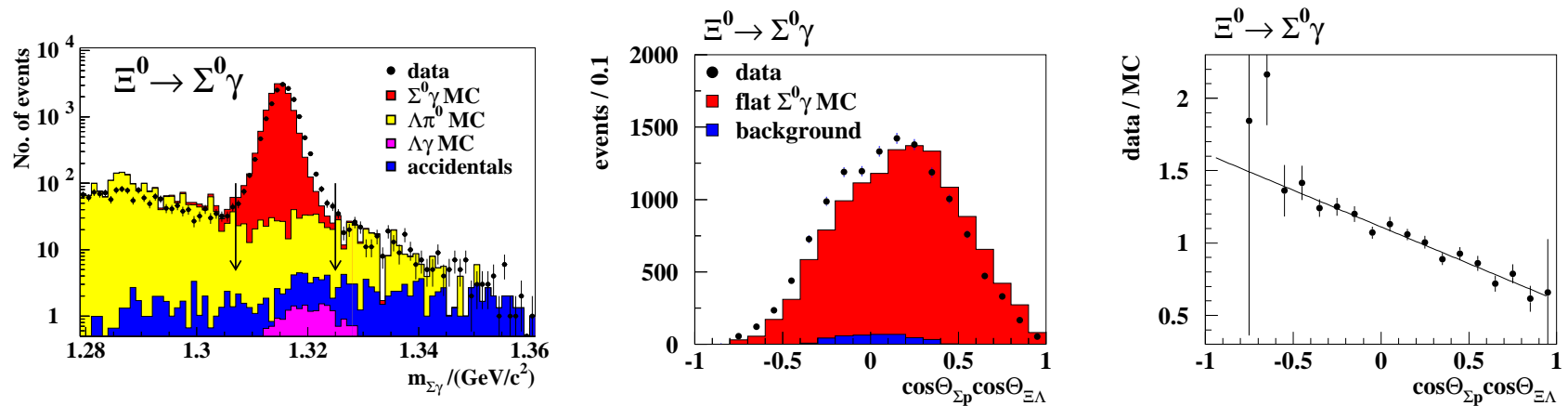

■ Fit result:  $\alpha_{\Xi^0 \rightarrow \Sigma^0 \gamma} \cdot \alpha_{\Lambda \rightarrow p \pi} = -0.438 \pm 0.020_{\text{stat}} \pm 0.041_{\text{syst}}$

(Again systematics mainly from energy dependence, trigger efficiency.)

■ Use  $\alpha_{\Lambda \rightarrow p \pi} = 0.642 \pm 0.013$  [PDG]: (NA48/1 preliminary)

$$\alpha_{\Xi^0 \rightarrow \Sigma^0 \gamma} = -0.682 \pm 0.031_{\text{stat}} \pm 0.065_{\text{syst}}$$

(Previous measurement:  $\alpha = -0.63 \pm 0.09$  [KTeV, 2001])

## $\Xi^0$ Lifetime:

- Important **input for other measurements** (e.g.  $|V_{us}|$  from  $\Xi^0$   $\beta$ -decays).
- Currently known to **less than 3% accuracy:**

$$\tau_{\Xi^0}(\text{PDG}) = (2.90 \pm 0.09) \times 10^{-10} \text{ s}$$

## NA48/1 Measurement:

- Use  $\Xi^0 \rightarrow \Lambda\pi^0$  events taken with **minimum bias trigger**.
  - ⇒ **~ 260 000 events**  
(virtually background-free)
- Fit in separate energy bins.
  - ⇒ No spectrum dependency.
- Fit region well separated from collimator position.
  - ⇒ No detector resolution effects.

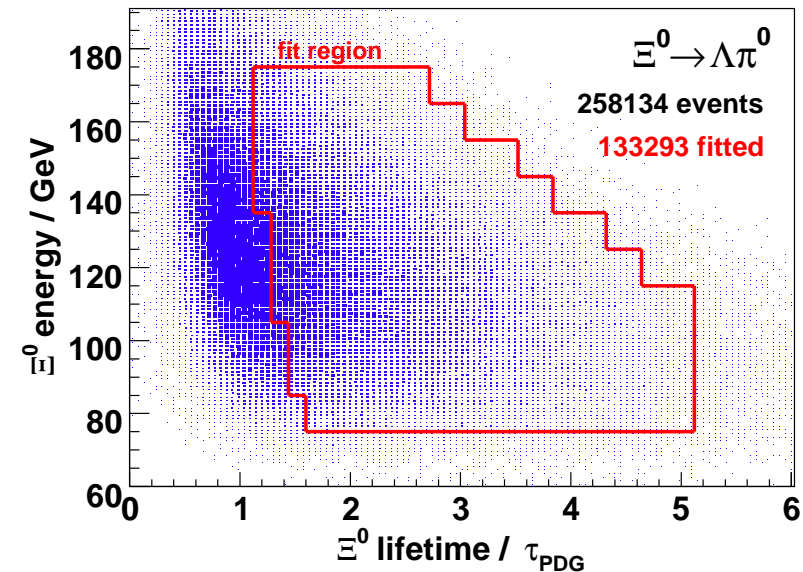

# $\Xi^0$ Lifetime

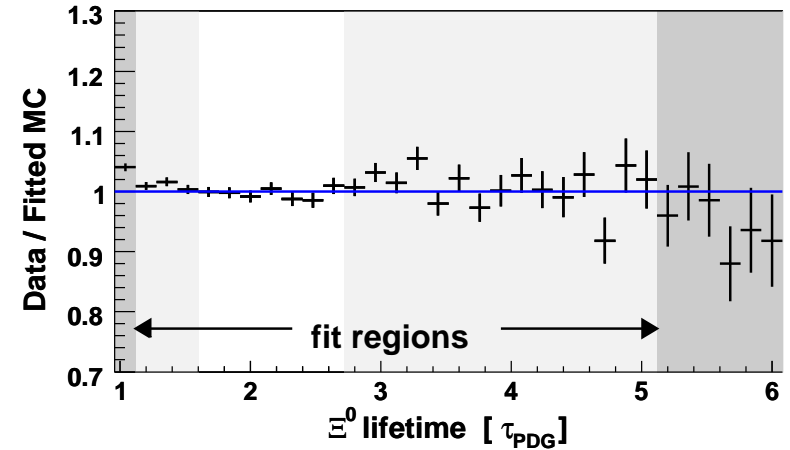
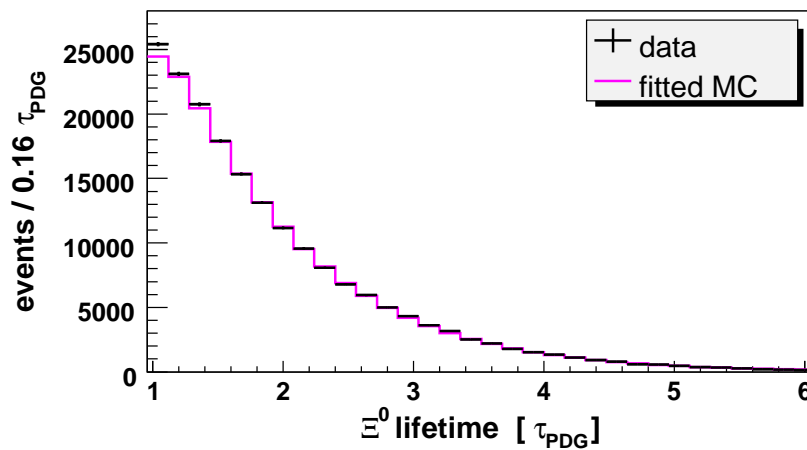

**Fit result:** *(preliminary)*

$$\tau_{\Xi^0} = (3.082 \pm 0.013 \pm 0.012) \cdot 10^{-10} \text{ s}$$

Systematics:

Detector accept.	$\pm 0.30\%$
Vertex resolution	$\pm 0.08\%$
LKr energy meas.	$\pm 0.17\%$
$\Xi^0$ polarisation	$\pm 0.15\%$
$\Xi^0$ mass	$\pm 0.20\%$

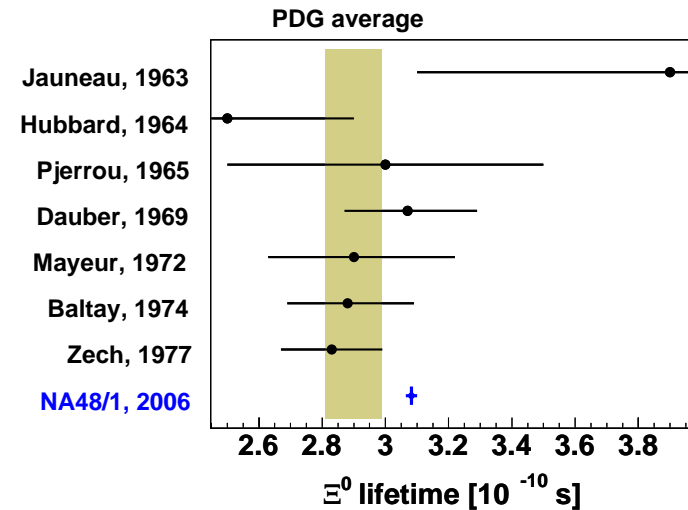

$\Rightarrow$  About  $2\sigma$  above PDG 2004 average, and five times more precise.

# $K^\pm$ Decays: The NA48/2 Experiment

Data taking in 2003/2004: (NA48/2 experiment)

- Main aim: Search for direct CP violation in  $K^\pm \rightarrow 3\pi$  decays.
- Simultaneous  $K^+$  and  $K^-$  beams, with  $p_{K^\pm} = (60 \pm 3) \text{ GeV}/c$ .
- Total statistics:  $K^\pm \rightarrow \pi^\pm \pi^+ \pi^-$ :  $\sim 4 \times 10^9$  events  
 $K^\pm \rightarrow \pi^\pm \pi^0 \pi^0$ :  $\sim 100 \times 10^6$  events

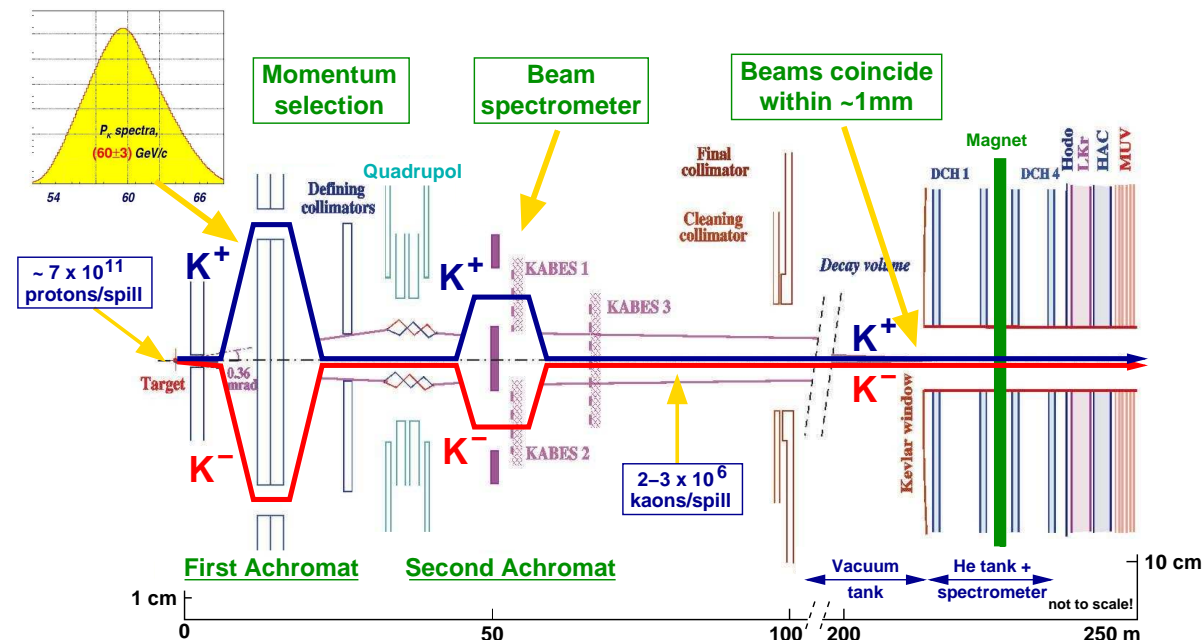

# Precise Measurement of $K^\pm \rightarrow \pi^\pm \pi^0 \gamma$

## Contributions to $K^\pm \rightarrow \pi^\pm \pi^0 \gamma$ :

- **Inner Bremsstrahlung** from  $K^\pm \rightarrow \pi^\pm \pi^0$ .
- **Direct Emission** from the vertex  
 $\implies \mathcal{O}(p^4)$  ChPT, both *electric* ( $E$ ) and *magnetic* ( $M$ ) dipole.
- **Interference** between **IB** and **DE**  
 $\implies$  sensitive to  $E$  only!

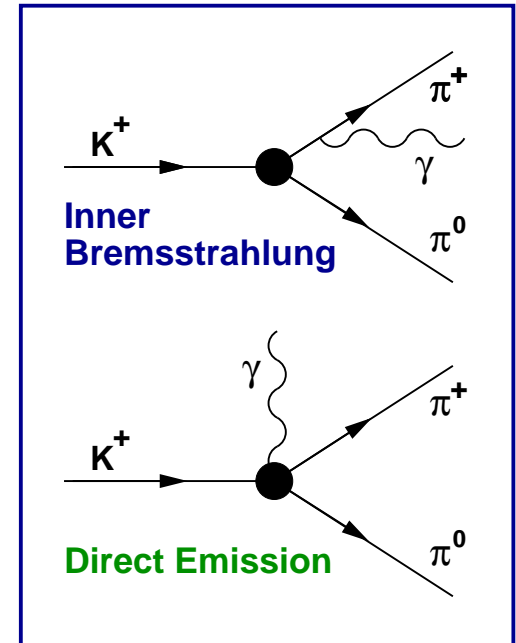

Sensitive variable:

$$\mathbf{W} = \frac{(\mathbf{p}_K^* \mathbf{p}_\gamma^*)(\mathbf{p}_\pi^* \mathbf{p}_\gamma^*)}{(m_K m_\pi)^2}$$

$$\frac{d\Gamma^\pm}{d\mathbf{W}} \simeq \underbrace{\frac{d\Gamma^\pm}{d\mathbf{W}}_{\text{IB}}}_{\text{Inner Brems.}} \left[ \mathbf{1} + \underbrace{2 \frac{m_\pi^2}{m_K^2} \mathbf{W}^2 |E| \cos(\delta_1 - \delta_0 \pm \phi)}_{\text{Interference}} + \underbrace{\frac{m_\pi^4}{m_K^4} \mathbf{W}^4 (|E|^2 + |M|^2)}_{\text{Direct Emission}} \right]$$

# Precise Measurement of $K^\pm \rightarrow \pi^\pm \pi^0 \gamma$

## Contributions separated in $W$ :

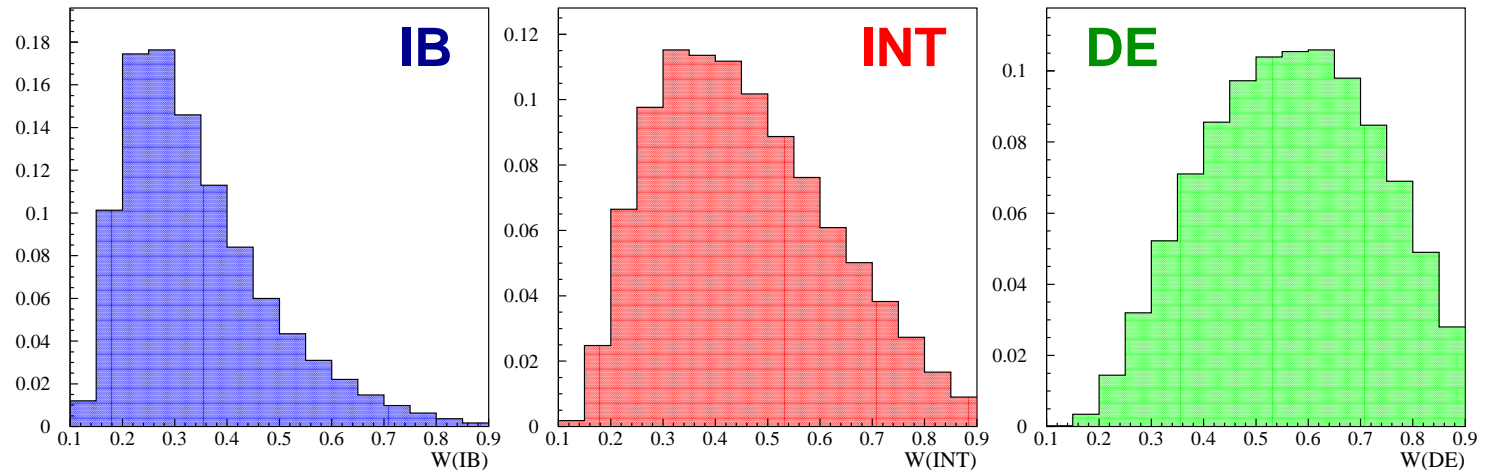

### Previous measurements:

(PDG 05,  $55 < T_\pi^* < 90$  MeV)

■ Inner Bremsstrahlung:

$$\text{Br} = (2.75 \pm 0.15) \times 10^{-4}$$

■ Direct Emission:

$$\text{Br} = (4.4 \pm 0.8) \times 10^{-4}$$

$$\implies \text{Frac(DE)} = (1.6 \pm 0.3)\%$$

■ Interference:

Not observed yet.

# Precise Measurement of $K^\pm \rightarrow \pi^\pm \pi^0 \gamma$

## Data selection:

- So far only **sub-sample of 2003 data** used (roughly 30% of all)
- Enlarge region in  $T_\pi^*$ :
 
$$0 < T_\pi^* < 80 \text{ MeV}$$
 (Previous exp's:  $55 < T_\pi^* < 90 \text{ MeV}$ )  
 $\implies$  More statistics and sensitivity to DE!
- Found: **210 000  $K^\pm \rightarrow \pi^\pm \pi^0 \gamma$**
- **Tiny backgrounds** ( $< 1\%$  of DE component).
- **Mistagging** (wrong gamma-pairing)  $\sim 0.1\%$ .

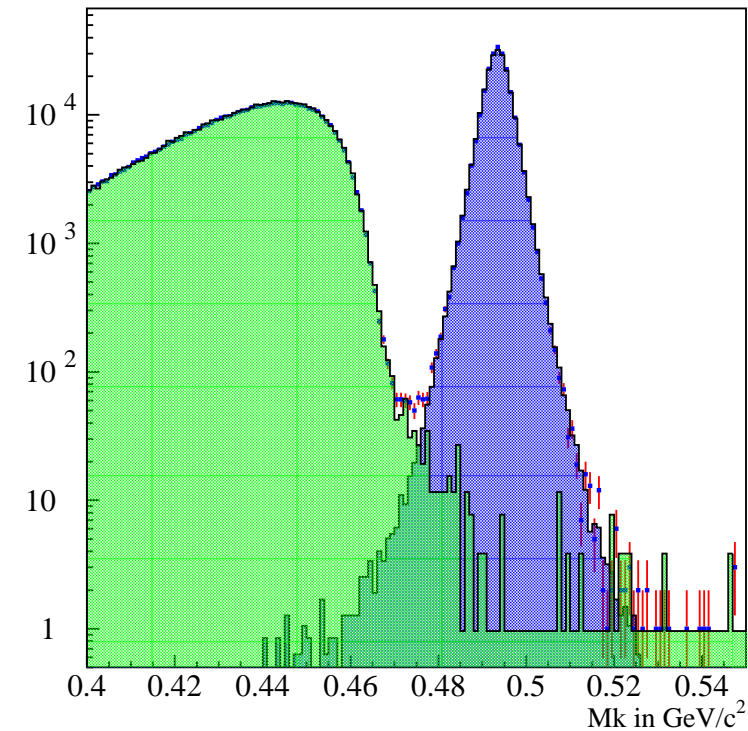

## Precise Measurement of $K^\pm \rightarrow \pi^\pm \pi^0 \gamma$

**Fit result:**

(NA48/2 preliminary)

$$\text{Frac(DE)} = (3.35 \pm 0.35 \pm 0.25)\%$$

$$\text{Frac(INT)} = (-2.67 \pm 0.81 \pm 0.73)\%$$

$$0 < T_\pi^* < 80 \text{ MeV}$$

**First evidence for  
non-zero interference term!**

- Correlation coefficient:  $\rho = -0.92$
- Systematics: dominated by trigger efficiency.
- For comparison with previous exp's:

$$\begin{aligned} \text{Frac(DE)}_{\text{INT}=0}^{\text{INT}=0} & \text{extrapolated to } 55 < T_\pi^* < 90 \text{ MeV} \\ & = (0.85 \pm 0.05 \pm 0.02)\% \end{aligned}$$

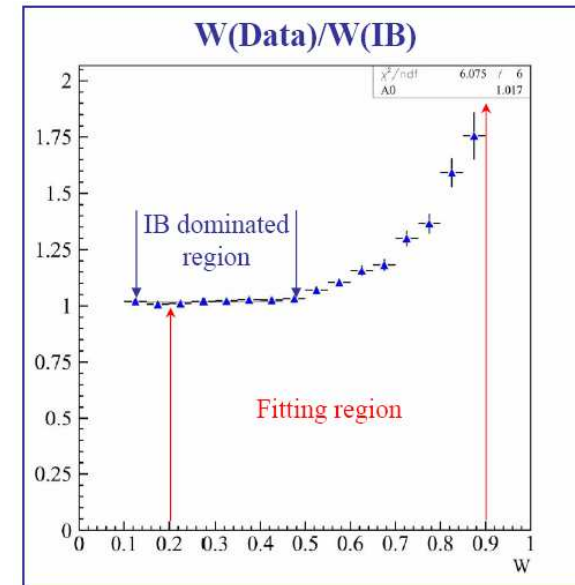

NA48/2 PRELIMINARY

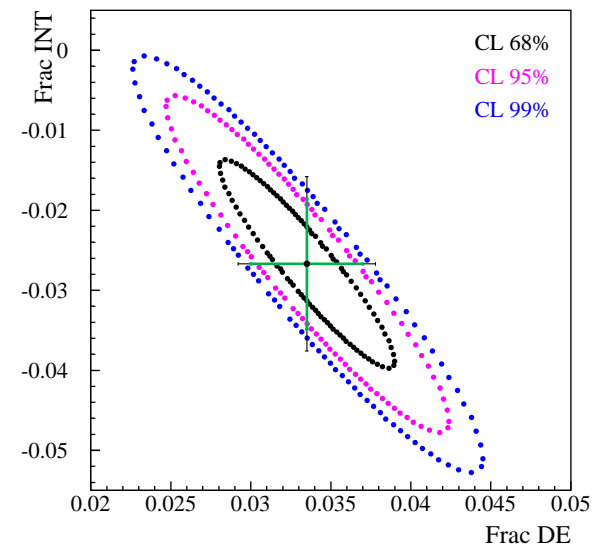

## Measurement of $K_{\mu 3}^0$ Form Factors

### Special minimum bias run in 1999:

- Pure  $K_L$  beam.
- **2.6 million**  $K_L^0 \rightarrow \pi\mu\nu$  ( $K_{\mu 3}^0$ ) taken with minimum bias trigger.
- Measurement of **slopes**  $\lambda_+$ ,  $\lambda_0$  of vector and scalar **form factors**  $f_+$ ,  $f_0$ .
- **Results:**

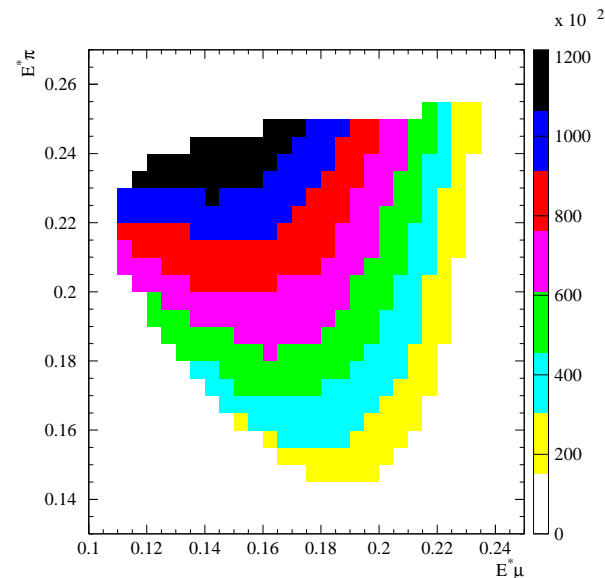

$$\lambda_+ = 0.0260 \pm 0.0007_{\text{stat}} \pm 0.0010_{\text{syst}}$$

$$\lambda_0 = 0.0120 \pm 0.0008_{\text{stat}} \pm 0.0015_{\text{syst}}$$

(preliminary)

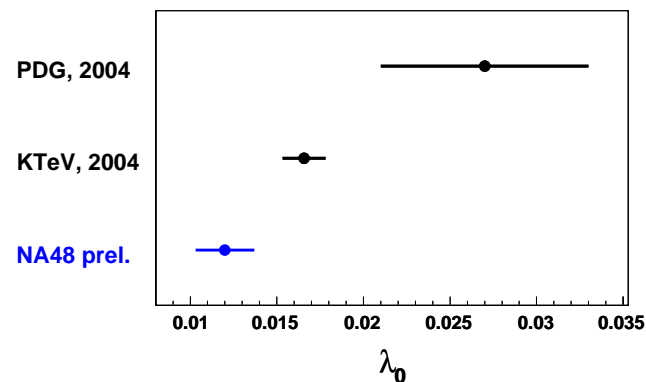
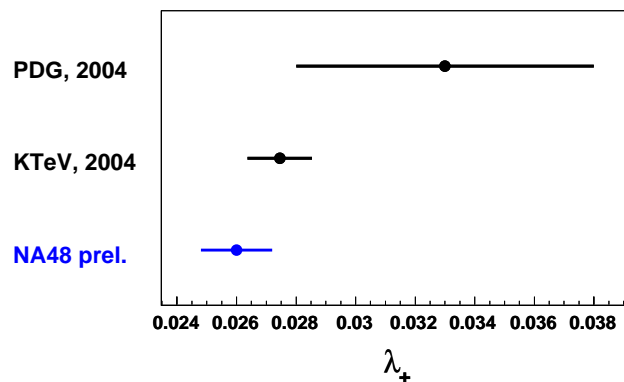

## Hyperon Decays:

- Precise measurements of  $\Xi^0 \rightarrow \Lambda/\Sigma^0 \gamma$  **decay asymmetries:**

$$\alpha_{\Xi^0 \rightarrow \Lambda \gamma} = -0.684 \pm 0.020_{\text{stat}} \pm 0.061_{\text{syst}}$$

$$\alpha_{\Xi^0 \rightarrow \Sigma^0 \gamma} = -0.682 \pm 0.031_{\text{stat}} \pm 0.065_{\text{syst}}$$

- New very precise measurement of the  $\Xi^0$  **lifetime:**

$$\tau_{\Xi^0} = (3.082 \pm 0.013 \pm 0.012) \cdot 10^{-10} \text{ s}$$

## Kaon Decays:

- First measurement of **interference term in  $K^\pm \rightarrow \pi^\pm \pi^0 \gamma$ :**

$$\text{Frac(DE)} = (3.35 \pm 0.35 \pm 0.25)\%$$

$$\text{Frac(INT)} = (-2.67 \pm 0.81 \pm 0.73)\%$$

- New measurement of  $K_{\mu 3}^0$  **form factors:**

$$\lambda_+ = 0.0260 \pm 0.0007_{\text{stat}} \pm 0.0010_{\text{syst}}$$

$$\lambda_0 = 0.0120 \pm 0.0008_{\text{stat}} \pm 0.0015_{\text{syst}}$$